

Heavy Duty Stock Sheave & Bushing Combinations

QD Sheaves & Bushings

- Sheaves available for belt sizes: A/B, C, 3V, 5V and 8V
- 1-12 groove
- Max. O.D. 63"
- Bushings stock in JA thru W sizes
- Bushings SH-W include a set screw in flange over keyway.
- Sheave/bushing can be reverse mounted (Bolts thru sheave then into bushing OR bolts thru bushing then into sheave)



DST Sheaves & Bushings

- Sheaves available for A/B section belts
- 1-4 groove
- Max. O.D. 38"
- DST sheaves offer more sizes from 3.75" O.D. up to 38.35" O.D. as compared to QD and TB.
- Bushings stock in G-H-P1-P2- Q1-Q2-R1 & R2
- Longest LTB (length thru bore) of all bushings
- Bushing and sheave use an additional key between the O.D. of bushing and I.D. of hub to transmit torque.



TB Sheaves & Bushings

- Sheaves available for A/B section belts
- 1-4 groove
- Max. O.D. 38"
- Bushings stock in sizes 1008 thru 5050
- No flange or hub
- Shortest LTB (length thru bore) of all bushings
- Flush mounting, no exposed bolts



**ALL bushings stocked in inch & metric sizes.
Rework machining available from Wisconsin.**

Manufactured to Industry Standard

H.D. Sheaves & Bushings for Every Application

Sheaves available for A/B, C, 3V, 5V and 8V belts, 1-12 groove

QD Bushings

QD Bushing - Dimensions (inches)						Φ d bolt Required	Cap Screws Grade 5 min.
Bushing	A	B	D	E	L		
JA	5/16	1.375	2	11/16	1	1.665	3-10 x 1
SH	7/16	1.871	2 11/16	7/8	1 5/16	2 1/4	3 1/4 x 1 3/8
SDS	7/16	2.187	3 1/8	7/8	1 5/16	2 11/16	3 1/4 x 1 3/8
SD	7/16	2.187	3 1/8	1 3/8	1 13/16	2 11/16	3 1/4 x 1 7/8
SK	9/16	2.812	3 7/8	1 3/8	1 15/16	3 5/16	3 5/16 x 2
SF	5/8	3.125	4 5/8	1 7/16	2 1/16	3 7/8	3 3/8 x 2
E	7/8	3.834	6	1 7/8	2 3/4	5	3 1/2 x 2 3/4
F	1	4.437	6 5/8	2 3/4	3 3/4	5 5/8	3 9/16 x 3 5/8
J	1 1/8	5.148	7 1/4	3 1/2	4 5/8	6 1/4	3 5/8 x 4 1/2
M	1 1/4	6.500	9	5 1/2	6 3/4	7 7/8	4 3/4 x 6 3/4
N	1 1/2	7.000	10	6 5/8	8 1/8	8 1/2	4 7/8 x 8
P	1 3/4	8.250	11 3/4	7 5/8	9 3/8	10	4 1 x 9 1/2
W	2	10.437	15	9 3/8	11 3/8	12 3/4	4 1 1/8 x 11 1/2

Note: All bushings include a set screw over the keyway. Except JA.

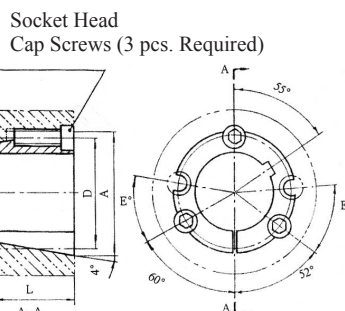
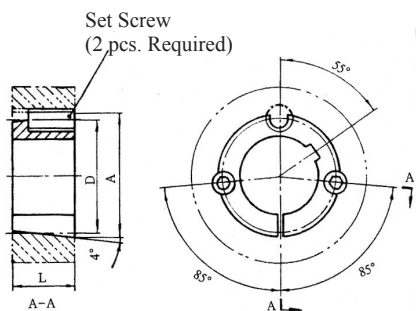
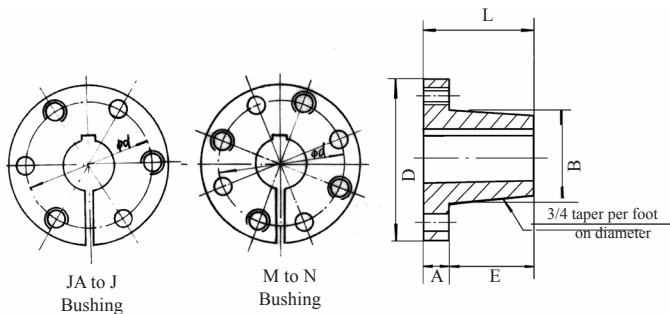

TB Bushings



Taper-Lock Bushing Dimensions				Set Screws Dia. x Length
Bushing	L	A	D	
1008	7/8	1.386	1 21/64	1/4-20 x 1/2
1108	7/8	1.511	1 29/64	1/4-20 x 1/2
1210	1	1.875	1 3/4	3/8-16 x 5/8
1215	1 1/2	1.875	1 3/4	3/8-16 x 5/8
1310	1	2.000	1 7/8	3/8-16 x 5/8
1610	1	2.250	2 1/8	3/8-16 x 5/8
1615	1 1/2	2.250	2 1/8	3/8-16 x 5/8
2012	1 1/4	2.750	2 5/8	7/16-14 x 7/8
2517	1 3/4	3.375	3 1/4	1/2-12 x 1
2525	2 1/2	3.375	3 1/4	1/2-12 x 1
3020	2	4.250	4	5/8-11 x 1 1/4
3030	3	4.250	4	5/8-11 x 1 1/4

Taper-Lock Bushing Dimensions				Set Screws Cap Screws Dia. x Length	E
Bushing	L	A	D		
3535	3 1/2	5	4.83	1/2-12 x 1 1/2	40°
4040	4	5 3/4	5.54	5/8-11 x 1 3/4	40°
4545	4 1/2	6 3/8	6.13	3/4-10 x 2	40°
5050	5	7	6.72	7/8-9 x 2 1/4	37°

Sheaves available for A/B section belts, 1-4 groove

Sheaves available for A/B section belts, 1-4 groove

DST BUSHINGS



H Bushing



Double Split Taper Bushing

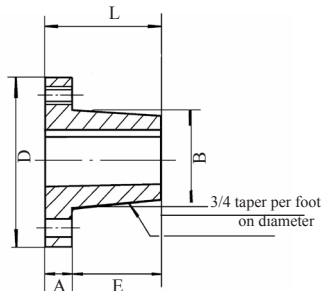
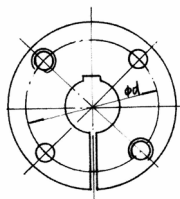

Double Split Taper Bushing - Dimensions (inches)						Φ d bolt Required	Cap Screws Grade 5 min.
Bushing	A	B	D	E	L		
G	1/4	1 11/64	2	3/4	1	1 9/16	2 1/4 x 5/8
H	11/32	1 5/8	2 1/2	1	1 11/32	2	2 1/4 x 1
H-STL	1/4	1 5/8	2 1/2	1	1 1/4	2	2 1/4 x 3/4
P1	13/32	1 15/16	3	1 17/32	1 15/16	2 7/16	3 5/16 x 1
P2	13/32	1 15/16	3	2 17/32	2 15/16	2 7/16	3 5/16 x 1
Q1	17/32	2 7/8	4 1/8	1 31/32	2 1/2	3 3/8	3 3/8 x 1 1/4
Q2	17/32	2 7/8	4 1/8	2 31/32	3 1/2	3 3/8	3 3/8 x 1 1/4
R1	5/8	4	5 3/8	2 1/4	2 7/8	4 5/8	3 3/8 x 1 3/4
R2	5/8	4	5 3/8	4 1/4	4 7/8	4 5/8	3 3/8 x 1 3/4

DST sheave and bushing combinations use an added external key between the hub and sheave.