

QD Bushings - Dimensions (inches)

Bushing	A	B	D	E	L	∅ d bolt Required	Cap Screws Grade 5
JA	5/16	1.375	2	11/16	1	1.665	3-10 x 1
SH	7/16	1.871	2 11/16	7/8	1 5/16	2 1/4	3-1/4 x 1 3/8
SDS	7/16	2.187	3 1/8	7/8	1 5/16	2 11/16	3-1/4 x 1 3/8
SD	7/16	2.187	3 1/8	1 3/8	1 13/16	2 11/16	3-1/4 x 1 7/8
SK	9/16	2.812	3 7/8	1 3/8	1 15/16	3 5/16	3-5/16 x 2
SF	5/8	3.125	4 5/8	1 7/16	2 1/16	3 7/8	3-3/8 x 2
E	7/8	3.834	6	1 7/8	2 3/4	5	3-1/2 x 2 3/4
F	1	4.437	6 5/8	2 3/4	3 3/4	5 5/8	3-9/16 x 3 5/8
J	1 1/8	5.148	7 1/4	3 1/2	4 5/8	6 1/4	3-5/8 x 4 1/2
M	1 1/4	6.500	9	5 1/2	6 3/4	7 7/8	4-3/4 x 6 3/4
N	1 1/2	7.000	10	6 5/8	8 1/8	8 1/2	4-7/8 x 8

Note: All bushings include a set screw over the keyway. Except H and JA.

Bushing	Bore Range-inch	Key Seat-inch
JA	7/16, 1/2, 9/16	1/8 x 1/16
	5/8, 11/16, 3/4, 13/16, 7/8	3/16 x 3/32
	15/16, 1	1/4 x 1/8
	1 1/16, 1 1/8, 1 3/16	1/4 x 1/16 *
	1 1/4	No Key
SH	1/2, 9/16	1/8 x 1/16
	5/8, 11/16, 3/4, 13/16, 7/8	3/16 x 3/32
	15/16, 1, 1 1/16, 1 1/8, 1 3/16, 1 1/4	1/4 x 1/8
	1 1/4†, 1 5/16, 1 3/8	5/16 x 5/32
	1 7/16, 1 1/2, 1 9/16, 1 5/8	3/8 x 1/16 *
	1 11/16	No Key
	SDS	1/2, 9/16
5/8, 11/16, 3/4, 13/16, 7/8		3/16 x 3/32
15/16, 1, 1 1/16, 1 1/8, 1 3/16, 1 1/4		1/4 x 1/8
1 1/4†, 1 5/16, 1 3/8		5/16 x 5/32
1 3/8†, 1 7/16, 1 1/2, 1 9/16, 1 5/8, 1 11/16		3/8 x 3/16
1 3/4		3/8 x 1/8 *
1 13/16		1/2 x 1/8 *
1 7/8, 1 15/16		1/2 x 1/16 *
2		No Key
SD		1/2, 9/16
	5/8, 11/16, 3/4, 13/16, 7/8	3/16 x 3/32
	15/16, 1, 1 1/16, 1 1/8, 1 3/16, 1 1/4	1/4 x 1/8
	1 1/4†, 1 5/16, 1 3/8	5/16 x 5/32
	1 3/8†, 1 7/16, 1 1/2, 1 9/16, 1 5/8, 1 11/16	3/8 x 3/16
	1 3/4	3/8 x 1/8 *
	1 13/16	1/2 x 1/8 *
	1 7/8, 1 15/16	1/2 x 1/16 *
	2	No Key
	SK	1/2, 9/16
5/8, 11/16, 3/4, 13/16, 7/8		3/16 x 3/32
1 5/16, 1, 1 1/16, 1 1/8, 1 3/16, 1 1/4		1/4 x 1/8
1 1/4†, 1 5/16, 1 3/8		5/16 x 5/32
1 5/16†, 1 3/8†, 1 7/16, 1 1/2, 1 9/16, 1 5/8		3/8 x 3/16
1 11/16, 1 3/4		3/8 x 3/16
1 3/4†, 1 13/16, 1 7/8, 1 15/16, 2, 2 1/16, 2 1/8		1/2 x 1/4
2 3/16, 2 1/4		1/2 x 1/8 *
2 1/4†, 2 5/16, 2 3/8, 2 7/16, 2 1/2		5/8 x 1/16 *
2 5/8, 2 9/16		No Key

Bushing	Bore Range-inch	Key Seat-inch
SF	1/2, 9/16	1/8 x 1/16
	5/8, 3/4, 7/8	3/16 x 3/32
	15/16, 1, 1 1/16, 1 1/8, 1 3/16, 1 1/4	1/4 x 1/8
	1 5/16, 1 3/8	5/16 x 5/32
	1 3/8†, 1 7/16, 1 1/2, 1 9/16, 1 5/8	3/8 x 3/16
	1 11/16, 1 3/4	3/8 x 3/16
	1 13/16, 1 7/8, 1 15/16, 2, 2 1/16	1/2 x 1/4
	2 1/8, 2 3/16, 2 1/4	1/2 x 1/4
	2 1/4†, 2 5/16, 2 3/8, 2 7/16, 2 1/2	5/8 x 3/16 *
	2 5/8, 2 11/16, 2 3/4, 2 9/16	5/8 x 1/16 *
	2 13/16, 2 7/8	3/4 x 1/16 *
2 15/16	No Key	
E	7/8, 15/16	3/16 x 3/32
	1, 1 1/8, 1 3/16, 1 1/4	1/4 x 1/8
	1 5/16, 1 3/8	5/16 x 5/32
	1 3/8†, 1 7/16, 1 1/2, 1 9/16, 1 5/8	3/8 x 3/16
	1 11/16, 1 3/4	3/8 x 3/16
	1 13/16, 1 7/8, 1 15/16, 2, 2 1/16	1/2 x 1/4
	2 1/8, 2 3/16, 2 1/4	1/2 x 1/4
	2 1/4†, 2 5/16, 2 3/8, 2 7/16, 2 1/2	5/8 x 5/16
	2 9/16, 2 5/8	5/8 x 5/16
	2 11/16, 2 3/4	5/8 x 5/16
	2 13/16, 2 7/8, 2 15/16, 3	3/4 x 1/8 *
3 1/8, 3 3/16, 3 1/4	3/4 x 1/8 *	
3 5/16, 3 3/8, 3 7/16	7/8 x 1/16 *	
3 1/2	7/8 x 1/16 *	

* Shallow Keyseat - Keystock supplied with bushing

† Oversize Key

Note: A rectangular key is supplied with bushings that have shallow keyseats. This key will fit the standard depth keyseat on the shaft and the shallow keyseat on the bushing.

Ordering Example: (JA1.1/16)

Bushing	Bore Range-inch	Key Seat- inch	
F	1, 1 1/8, 1 3/16, 1 1/4	1/4 x 1/8	
	1 3/8	5/16 x 5/32	
	1 7/16, 1 1/2, 1 9/16, 1 5/8, 1 11/16, 1 3/4	3/8 x 3/16	
	1 13/16, 1 7/8, 1 15/16, 2, 2 1/16	1/2 x 1/4	
	2 1/8, 2 3/16, 2 1/4	1/2 x 1/4	
	2 1/4†, 2 5/16, 2 3/8, 2 7/16, 2 1/2, 2 5/8, 2 9/16	5/8 x 5/16	
	2 11/16, 2 3/4	5/8 x 5/16	
	2 13/16, 2 7/8, 2 15/16, 3	3/4 x 3/8	
	3 1/8, 3 3/16, 3 1/4	3/4 x 3/8	
	3 5/16, 3 3/8, 3 7/16, 3 1/2	7/8 x 3/16 *	
	3 5/8, 3 11/16, 3 3/4	7/8 x 3/16 *	
	3 7/8, 3 15/16	1 x 1/8 *	
	4	No Key	
	J	1 7/16, 1 1/2, 1 11/16, 1 3/4	3/8 x 3/16
1 7/8, 1 15/16, 2, 2 1/16		1/2 x 1/4	
2 1/8, 2 3/16, 2 1/4		1/2 x 1/4	
2 5/16, 2 3/8, 2 7/16, 2 1/2, 2 5/8		5/8 x 5/16	
2 11/16, 2 3/4		5/8 x 5/16	
2 7/8, 2 15/16, 3		3/4 x 3/8	
3 1/8, 3 3/16, 3 1/4		3/4 x 3/8	
3 5/16, 3 3/8, 3 7/16, 3 1/2,		7/8 x 7/16	
3 5/8, 3 11/16, 3 3/4		7/8 x 7/16	
3 13/16, 3 7/8, 3 15/16		1 x 3/8 *	
4, 4 1/8, 4 3/16, 4 1/4, 4 3/8, 4 7/16, 4 1/2		1 x 1/8 *	
M		1 15/16, 2	1/2 x 1/4
		2 3/16, 2 1/4	1/2 x 1/4
		2 3/8, 2 7/16, 2 1/2, 2 5/8	5/8 x 5/16
	2 11/16, 2 3/4	5/8 x 5/16	
	2 7/8, 2 15/16, 3	3/4 x 3/8	
	3 1/8, 3 3/16, 3 1/4	3/4 x 3/8	
	3 3/8, 3 7/16, 3 1/2	7/8 x 7/16	
	3 5/8, 3 11/16, 3 3/4	7/8 x 7/16	
	3 13/16, 3 7/8, 3 15/16	1 x 1/2	
	4, 4 1/8, 4 3/16, 4 1/4, 4 3/8, 4 7/16, 4 1/2	1 x 1/2	
	4 5/8, 4 11/16, 4 3/4,	1 1/4 x 5/8	
	4 7/8, 4 15/16,	1 1/4 x 1/4 *	
	5, 5 3/16, 5 1/4, 5 3/8, 5 7/16, 5 1/2	1 1/4 x 1/4 *	
	N	2 15/16, 3	3/4 x 3/8
3 3/8, 3 7/16, 3 1/2		7/8 x 7/16	
3 5/8, 3 3/4		7/8 x 7/16	
3 7/8, 3 15/16		1 x 1/2	
4, 4 3/16, 4 1/4, 4 3/8, 4 7/16, 4 1/2		1 x 1/2	
4 3/4		1 1/4 x 5/8	
4 7/8, 4 15/16, 5		1 1/4 x 5/8	
5 3/16, 5 7/16, 5 1/2		1 1/4 x 1/4 *	
5 7/8		1 1/2 x 1/4 *	

Replacement Bolt Kits for Bushings			
Bushing	Bolt Kit P/N	Bushing	Bolt Kit P/N
H	HBK	SF	SFBK
JA	JABK	E	EBK
SH	SHBK	F	FBK
SDS	SDSBK	J	JBK
SD	SDBK	M	MBK
SK	SKBK		

Note: Each kit contains bolts and washers for one bushing.

Bushing	Bore Range-mm	Key-mm
JA	15, 16	5 x 2.3
	19, 20, 22	6 x 2.8
	24, 25, 28	8 x 2.0
SH	15	5 x 2.3
	20, 22	6 x 2.8
	24, 25,	8 x 2.0
	30	8 x 7
	32, 35, 38	10 x 8
SDS	24, 25, 28, 30	8 x 7
	32, 35, 38	10 x 8
	40, 42	12 x 8
SD	24, 25, 28, 30	8 x 7
	32, 35, 38	10 x 8
	40, 42	12 x 8
SK	14	5 x 5
	20	6 x 6
	24, 25, 28, 30	8 x 7
	32, 35, 38	10 x 8
	40, 42	12 x 8
	45, 48, 50	14 x 9
	55	16 x 10
60	18 x 11	
SF	28, 30	8 x 7
	32, 35, 38	10 x 8
	40, 42	12 x 8
	45, 48, 50	14 x 9
	55	16 x 10
	60, 65	18 x 11
E	35, 38	10 x 8
	40, 42	12 x 8
	45, 48, 50	14 x 9
	55	16 x 10
	60, 65	18 x 11
	70, 75	20 x 12
	80	22 x 14
F	42	12 x 8
	45, 48, 50	14 x 9
	55	16 x 10
	60, 65	18 x 11
	70, 75	20 x 12
	80, 85	22 x 14
	90	25 x 14
J	50	14 x 9
	55	16 x 10
	60, 65	18 x 11
	70, 75	20 x 12
	80, 85	22 x 14
	90, 95	25 x 14
	100	28 x 16
M	80	22 x 14
	90	25 x 14
	100	28 x 16
	120	32 x 18
N	100	28 x 16
	120	32 x 18

Note: The Metric System does not refer to the keyseat or keyway dimensions as does the English System. Instead dimensions are given for the key itself which is rectangular in shape *Not Square* as in the English System.

Ordering Example: (H10MM) or (E35MM)

* Shallow Keyseat - Keystock supplied with bushing
† Oversize Key

Note: A rectangular key is supplied with bushings that have shallow keyseats. This key will fit the standard depth keyseat on the shaft and the shallow keyseat on the bushing.

Ordering Example: (F1) or (F1.1/8) or (N5.7/8)

QD bushing sizes JA through J can be assembled in either of the two positions shown below. Sizes M through S should be assembled in position one. *Position One* is the conventional or standard mounting. *Position Two* (Reverse Mounting) may be necessary in some cases, such as mounting small sheaves with blind holes (not drilled through).

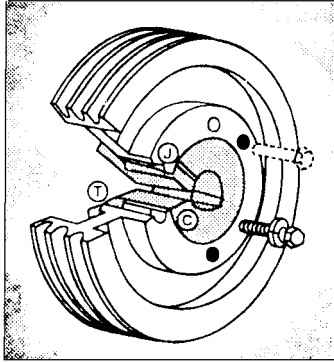

Position 1

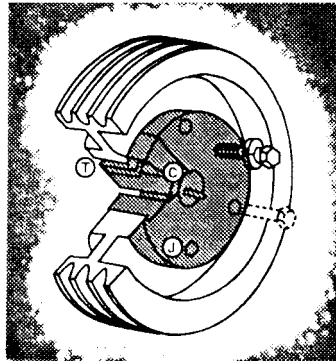

Position 2

Bushing Size	Cap Screw Size-Thread	Foot Pounds Wrench Torque*
JA	10-24	3
SH-SDS-SD	1/4-20	6
SK	5/16-18	10
SF	3/8-16	20
E	1/2-13	40
F	9/16-12	50
J	5/8-11	90
M	3/4-10	150
N	7/8-9	200
P	1-8	300
W	1-1/8-7	400
S	1-1/4-7	500

*For Normal Applications. For Severe (Rock-crusher type) applications these values can be increased by a maximum of 50%
Caution: Excessive cap-screw torque can cause sheave and/or bushing breakage. The use of lubricants can cause sheave breakage. Therefore,

DO NOT USE LUBRICANTS IN THIS INSTALLATION!

INSTALLATION:

1. Make sure the tapered-cone surface of the bushing and the mating bore of the sheave are free of all foreign substances, such as dirt, excess paint accumulations, metal chips, lubricants, etc.
2. For position one or two (whichever applies), line up the unthreaded holes (C) with the threaded holes (t) and insert cap screws with lock washers engaging only two or three threads. (*a)
3. With key in shaft keyway, slide the loosely-assembled unit onto shaft and position for good belt alignment. (*b, *c) **Use no lubricants or anti-seize compound on threads or tapered surfaces.**
4. Carefully tighten the capscrews alternately and progressively until the tapers are seated (at approximately half the recommended torque).
5. Check alignment and sheave runout (wobble) and correct as necessary.
6. Continue careful alternate and progressive tightening of the cap screws to the recommended torque values shown in the table. **Maximum torque should be achieved on each individual bolt only two times in the consecutive tightening.**

Note: When properly mounted, there will be a gap between the bushing flange and sheave after the screws are tightened.

Caution: Use of Lubricants and or excessive screw torque can cause breakage

7. Tighten the set screw, when available, to hold the key securely during operation.

REMOVAL

1. Loosen and remove all mounting cap screws.
2. Insert cap screws in all threaded jack screw holes (J).
3. Start with the screws furthest from the bushing saw slot and tighten all jack screws alternately and progressively. Keep turning the screws in small equal amounts until the tapered surfaces disengage.

(*a) When mounting a sheave on M through W size bushing, position the threaded jack-apart hole (J) as far from the bushing saw as possible to reduce the possibility of bushing breakage.

(*b) When installing large or heavy parts in *Position One*, it may be easier to mount the key and bushing on the shaft first. Then place the sheave on the bushing and align the holes.

(*c) **Caution:** When mounting on a vertical shaft, provisions must be made, which will positively prevent the sheave and/or bushing from dropping during installation.