

DOUBLE SPLIT TAPER BUSHINGS

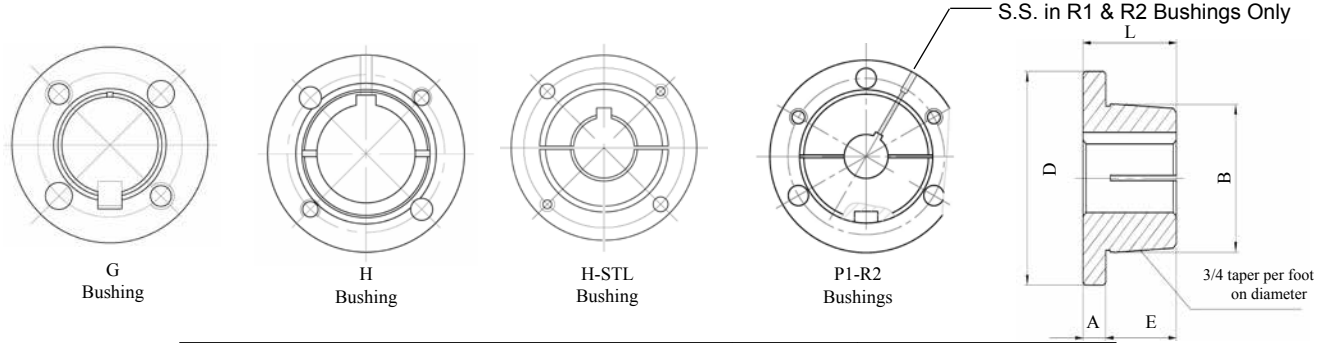

Double Split Taper Bushing - Dimensions (inches)						I d bolt Required	Cap Screws Grade 5 Min.	
Bushing	A	B	D	E	L		Qty.	Size
G	1/4	1.172	2	3/4	1	1 9/16	2	1/4 x 5/8
H*	11/32	1 5/8	2 1/2	1	1 11/32	2	2	1/4 x 1
H-STL**	1/4	1 5/8	2 1/2	1	1 1/4	2	2	1/4 x 3/4
P1	13/32	1 15/16	3	1 17/32	1 15/16	2 7/16	3	5/16 x 1
P2	13/32	1 15/16	3	2 17/32	2 15/16	2 7/16	3	5/16 x 1
Q1	17/32	2 7/8	4 1/8	1 31/32	2 1/2	3 3/8	3	3/8 x 1 1/4
Q2	17/32	2 7/8	4 1/8	2 31/32	3 1/2	3 3/8	3	3/8 x 1 1/4
R1	5/8	4	5 3/8	2 1/4	2 7/8	4 5/8	3	3/8 x 1 3/4
R2	5/8	4	5 3/8	4 1/4	4 7/8	4 5/8	3	3/8 x 1 3/4

*Standard H bushings are made out of powdered metal and include a set screw over the keyway.

**STL H bushings are optional and are made out of steel. These do not have a set screw.

Bushing	Bore Range-inch	Wt.	Key Seat- inch
G	3/8, 7/16,	0.40	None
	1/2, 9/16	0.40	1/8 x 1/16
	5/8, 11/16, 3/4, 13/16, 7/8	0.40	3/16 x 3/32
	15/16, 1	0.40	1/4 x 1/16 *
H	3/8**, 7/16**,	0.90	None
	1/2**, 9/16**	0.90	1/8 x 1/16
	5/8, 11/16, 3/4, 13/16, 7/8	0.90	3/16 x 3/32
	15/16, 1, 1 1/16, 1 1/8, 1 3/16, 1 1/4	0.90	1/4 x 1/8
	1 5/16, 1 3/8	0.90	5/16 x 1/16 *
	1 3/8†, 1 7/16**, 1 1/2**	0.90	3/8 x 1/16 *
P1	1/2, 9/16,	1.70	1/8 x 1/16
	5/8, 21/32, 11/16, 3/4, 25/32, 13/16, 7/8	1.70	3/16 x 3/32
	15/16, 31/32, 1, 1 1/16, 1 1/8, 1 3/16, 1 1/4	1.70	1/4 x 1/8
	1 5/16, 1 3/8	1.70	5/16 x 5/32
	1 7/16, 1 1/2, 1 5/8, 1 11/16, 1 3/4	1.70	3/8 x 3/16
P2	3/4, 13/16, 7/8	2.18	3/16 x 3/32
	15/16, 1, 1 1/16, 1 1/8, 1 3/16, 1 1/4	2.18	1/4 x 1/8
	1 5/16, 1 3/8	2.18	5/16 x 5/32
	1 7/16*, 1 1/2, 1 9/16, 1 5/8, 1 11/16	2.18	3/8 x 3/16
Q1	3/4, 13/16, 7/8	4.60	3/16 x 3/32
	15/16, 1, 1 1/16, 1 1/8, 1 3/16, 1 1/4,	4.60	1/4 x 1/8
	1 5/16, 1 3/8	4.60	5/16 x 5/32
	1 7/16, 1 1/2, 1 9/16, 1 5/8, 1 11/16, 1 3/4	4.60	3/8 x 3/16
	1 13/16, 1 7/8, 1 15/16, 2, 2 1/16, 2 1/8, 2 3/16, 2 1/4	4.60	1/2 x 1/4
	2 5/16, 2 3/8, 2 7/16, 2 1/2, 2 9/16, 2 5/8, 2 11/16	4.60	5/8 x 5/16

Bushing	Bore Range-inch	Wt.	Key Seat- inch
Q2	1, 1 1/16, 1 1/8, 1 3/16, 1 1/4	5.80	1/4 x 1/8
	1 5/16, 1 3/8	5.80	5/16 x 5/32
	1 7/16, 1 1/2, 1 9/16, 1 5/8, 1 11/16, 1 3/4	5.80	3/8 x 3/16
	1 13/16, 1 7/8, 1 15/16, 2	5.80	1/2 x 1/4
	2 1/16, 2 1/8, 2 3/16, 2 1/4	5.80	1/2 x 1/4
	2 5/16, 2 3/8, 2 7/16, 2 1/2, 2 9/16,	5.80	5/8 x 5/16
R1	1 1/8, 1 3/16, 1 1/4	9.95	1/4 x 1/8
	1 5/16, 1 3/8,	9.95	5/16 x 5/32
	1 7/16	9.95	3/8 x 3/16
	1 1/2, 1 9/16, 1 5/8, 1 11/16, 1 3/4	9.95	3/8 x 3/16
	1 13/16, 1 7/8, 1 15/16, 2, 2 1/16, 2 1/8, 2 3/16, 2 1/4	9.95	1/2 x 1/4
	2 5/16, 2 3/8, 2 7/16, 2 1/2	9.95	5/8 x 5/16
	2 9/16, 2 5/8, 2 11/16, 2 3/4	9.95	5/8 x 5/16
	2 13/16, 2 7/8, 2 15/16, 3, 3 1/8, 3 3/16, 3 1/4	9.95	3/4 x 3/8
	3 3/8, 3 7/16, 3 1/2, 3 5/8, 3 3/4	9.95	7/8 x 7/16
R2	1 3/8	14.38	5/16 x 5/32
	1 7/16, 1 1/2, 1 9/16, 1 5/8, 1 11/16, 1 3/4	14.38	3/8 x 3/16
	1 13/16, 1 7/8, 1 15/16, 2, 2 1/16, 2 1/8, 2 3/16, 2 1/4	14.38	1/2 x 1/4
	2 5/16, 2 3/8, 2 7/16, 2 1/2	14.38	5/8 x 5/16
	2 9/16, 2 5/8, 2 11/16, 2 3/4	14.38	5/8 x 5/16
	2 13/16, 2 7/8, 2 15/16, 3, 3 1/8, 3 3/16, 3 1/4	14.38	3/4 x 3/8
	3 3/8, 3 7/16, 3 1/2, 3 5/8, 3 3/4	14.38	7/8 x 7/16

* Shallow Keyseat - Keystock supplied with bushing

** These H bushings are only available in steel.

† Oversize Key

Note: A rectangular key is supplied with bushings that have shallow keyseats. This key will fit the standard depth keyseat on the shaft and the shallow keyseat on the bushing.

Ordering Example: (P1-1) or (Q1-1.1/16) or (H1-1/16) or (H1-1/16-STL)

All sizes except H are made out of **Ductile Iron**.

DOUBLE SPLIT TAPER BUSHINGS

DOUBLE SPLIT TAPER BUSHINGS INSTALLATION INSTRUCTIONS



Bushing	Bore Range-mm	Key Seat-mm	Wt.
G	10, 11, 12,	No Key	0.4
	14,16,	5 x 2.3	0.4
	18, 19, 20, 22,	6 x 2.8	0.4
	24, 25	8 x 3.3	0.4
H	10**, 11**	No Key	0.9
	14**, 15**, 16, 17	5 x 2.3	0.9
	18, 19, 20, 22	6 x 2.8	0.9
	24, 25, 28, 30	8 x 3.3	0.9
	32**, 35**	10 x 3.3	0.9
P1	14, 15, 16,	5 x 2.3	1.7
	18, 19, 20, 22	6 x 2.8	1.7
	24, 25, 28, 30	8 x 3.3	1.7
	32, 35, 36, 38,	10 x 3.3	1.7
	39, 40, 42	12 x 3.3	1.7
Q1	18, 19, 20, 22	6 x 2.8	4.60
	24, 25, 28, 30	8 x 3.3	4.60
	32, 35, 36, 38,	10 x 3.3	4.60
	40, 42	12 x 3.3	4.60
	45, 48, 50	14 x 3.8	4.60
	55	16 x 4.3	4.60
	60, 65	18 x 4.4	4.60
R1	28, 30	8 x 3.3	9.95
	32, 35, 36, 38	10 x 3.3	9.95
	39, 40, 42	12 x 3.3	9.95
	45, 48, 50	14 x 3.8	9.95
	55	16 x 4.3	9.95
	60, 65	18 x 4.4	9.95
	70, 75	20 x 4.9	9.95
	80, 85	22 x 5.4	9.95
	90, 95	25 x 5.4	9.95
R2	35, 36, 38	10 x 3.3	14.38
	39, 40, 42	12 x 3.3	14.38
	45, 48, 50	14 x 3.8	14.38
	55	16 x 4.3	14.38
	60, 65	18 x 4.4	14.38
	70, 75	20 x 4.9	14.38
	80, 85,	22 x 5.4	14.38
	90	25 x 5.4	14.38

INSTALLATION

1. Properly clean shaft, bore and taper surfaces of bushing. Remove and degrease any excess oil, paint or dirt, this includes the cap screws. Caution: Excessive cap screw torque can cause sheave or bushing breakage. The use of lubricants can cause sheave breakage. DO NOT USE LUBRICANTS OF ANY TYPE WITH THIS INSTALLATION.
2. Install the bushing into the hub and match the unthreaded bushing holes with the threaded holes of the hub. Install the cap screws and lock washers through the unthreaded holes and into the threaded holes of the hub. Engage only a few threads by hand – Do not use a wrench.
3. Install key into the keyway of the shaft and fit assembly onto the shaft and locate in the proper location.
4. Tighten cap screws alternately and gradually. Tighten cap screws to the recommended Wrench Torque Value using a torque wrench.

REMOVAL

Remove cap screws and insert into the tapped holes in the bushing. Tighten them alternately and gradually until the bushing disengages from the hub.

Recommended Wrench Torque		
Bushing #	lb-in	lb-ft
G	95	8
H	95	8
P1	192	16
P2	192	16
Q1	348	29
Q2	348	29
R1	348	29
R2	348	29

** These H bushings are only available in steel.