

MPTA-B6i-2010

Quick Detachable Bushing & Mating Hub
Standard

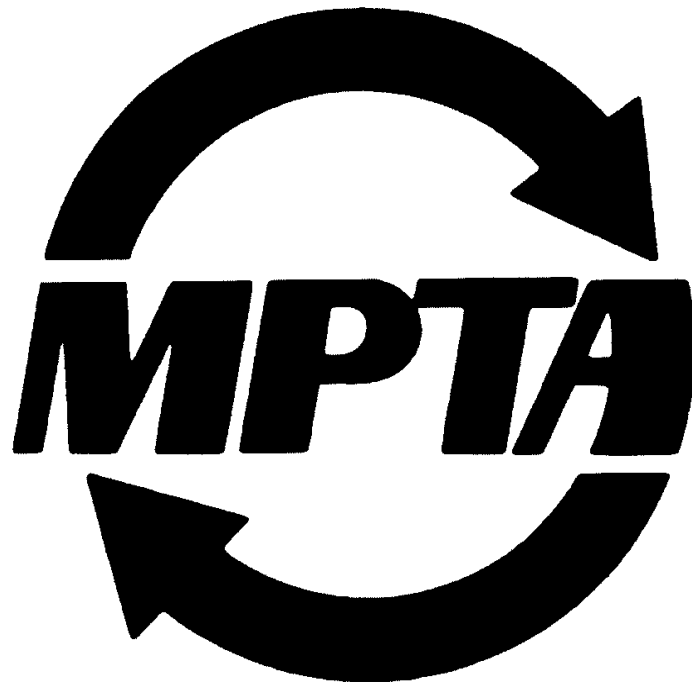

MPTA Standard

Contributors

B&B Manufacturing	LaPorte, In	www.bbman.com
Baldor Dodge Reliance & Maska	Greenville SC	www.baldor.com
Carlisle Power Transmission Products, Inc.	Miamisburg, OH	www.cptbelts.com
Custom Machine & Tool Co., Inc.	East Weymouth, MA	www.cmtco.com
Diamond Precision Products	Johnson Creek, WI	www.diamondprecision.com
Emerson Power Transmission	Maysville, KY	www.emerson-ept.com
Gates Corporation	Denver, CO	www.gates.com
Goldens' Foundry & Machine Co.	Columbus, GA	www.gfmco.com
Goodyear Engineerd Products	Lincoln, NE	www.goodyearep.com
Lovejoy, Inc	Downers Grove, IL	www.lovejoy-inc.com
Martin Sprocket & Gear, Inc.	Arlington, TX	www.martinsprocket.com
Maurey Manufacturing Corp.	Holly Springs, MS	www.maurey.com
New Hampshire Industries H.Neuman & Company Myers Manufacturing	Lebanon, NH Schiller Park, IL	www.nhipulley.com www.hneuman.com
TB Wood's Incorporated	Chambersburg, PA	www.tbwoods.com
Torque Transmission Fairport	Harbor, OH	www.torquetrans.com

Disclaimer Statement

This publication is presented for the purpose of providing reference information only. You should not rely solely on the information contained herein. Mechanical Power Transmission Association (MPTA) recommends that you consult with appropriate engineers and / or other professionals for specific needs. Again, this publication is for reference information only and in no event will MPTA be liable for direct, indirect, incidental, or consequential damages arising from the use of this information

Abstract

This standard provides general dimensions and tolerances for inch quick detachable bushings and mating hubs.

Copyright Position Statement

MPTA publications are not copyrighted to encourage their use throughout industry. It is requested that the MPTA be given recognition when any of this material is copied for any use.

Foreword

This Foreword is provided for informational purposes only and is not to be construed to be part of any technical specification.

This standard is a revision of QD-1-1992. It has been re-formatted for consistency with other MPTA documents.

Suggestions for the improvement of, or comments on this publication are welcome. They should be mailed to Mechanical Power Transmission Association, 6724 Lone Oak Blvd., Naples, FL 34109 on your company letterhead.

Scope

This guideline is intended to provide dimensions and tolerances, which will permit bushings made by one manufacturer to be used to mount sheaves or other products made by a different manufacturer.

The bushing system described in this guideline is limited to systems having the following characteristics:

- ... An external flange
- ... No external key
- ... A nominal $\frac{3}{4}$ inch/foot taper
- ... Split through both flange and taper
- ... Conventional and reverse mount capability.

Table 1 -Detachable Bushings

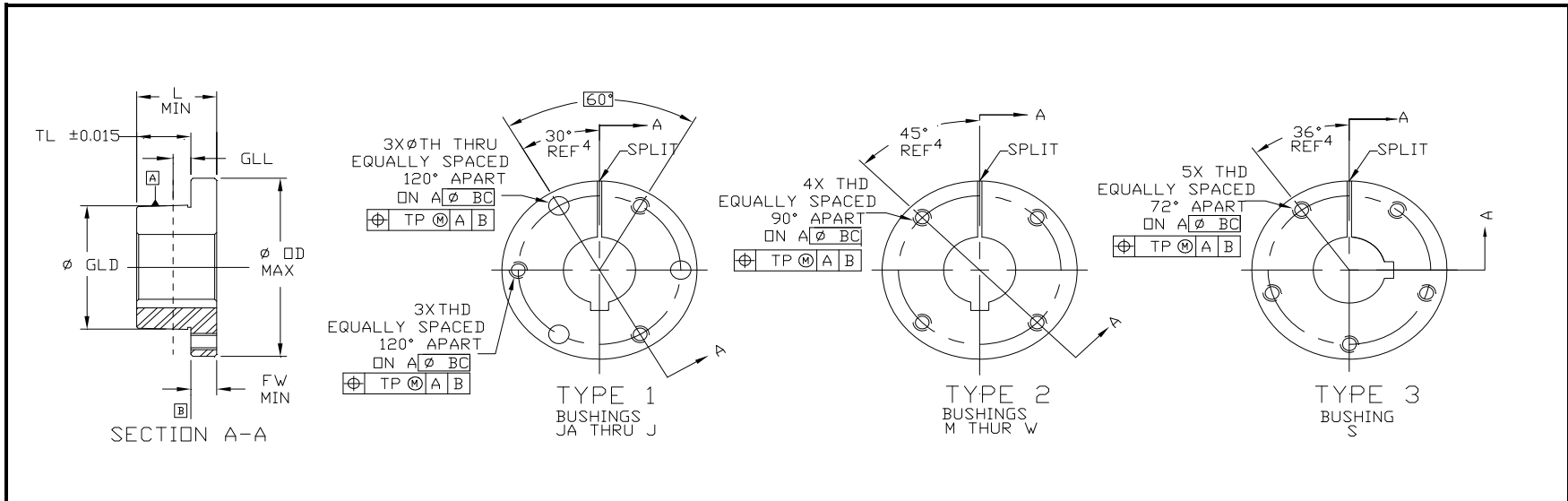

BUSHING	BUSHING TYPE	DIMENSIONS (IN)									
		GAGE LINE		FLANGE WIDTH FW	OUTSIDE DIAMETER OD	TAPER LENGTH TL	BUSHING LENGTH L	THREADED HOLE THREAD SIZE THD	THRU HOLE MIN DIAMETER TH	THREADED AND THRU HOLE	
		DIAMETER GLD	LOCATION GLL							BOLT CIRCLE DIAMETER BC	TRUE POSITION TP
JA	1	1.3750	.1860 / .2340	0.30	2.02	0.56	0.80	#10-24 UNC-2B	0.2189	1.6560	0.007
SH	1	1.8710	.2120 / .2740	0.36	2.70	0.81	1.17	1/4-20 UNC-2B	0.2813	2.2500	0.007
SDS	1	2.1875	.2320 / .2980	0.42	3.20	0.88	1.30	1/4-20 UNC-2B	0.3125	2.6875	0.007
SD	1	2.1875	.2220 / .2980	0.42	3.20	1.38	1.80	1/4-20 UNC-2B	0.3125	2.6875	0.007
SK	1	2.8125	.2580 / .3765	0.48	3.89	1.25	1.67	5/16-18 UNC-2B	0.3438	3.3125	0.007
SF	1	3.1250	.2680 / .3765	0.48	4.64	1.44	1.98	3/8-16 UNC-2B	0.4375	3.8750	0.015
E	1	3.8340	.2780 / .3765	0.73	6.02	1.88	2.61	1/2-13 UNC-2B	0.5625	5.0000	0.015
F	1	4.4375	.3750 / .4710	0.80	6.64	2.75	3.61	9/16-12 UNC-2B	0.6250	5.6250	0.015
J	1	5.1484	.3750 / .4710	0.98	7.27	3.50	4.48	5/8-11 UNC-2B	0.6875	6.2500	0.015
M	2	6.5000	.3750 / .4710	1.23	9.14	5.50	6.73	3/4-10 UNC-2B	.8125 (3)	7.8750	0.015
N	2	7.0000	.3750 / .4710	1.48	10.02	6.63	8.11	7/8-9 UNC-2B	.9375 (3)	8.5000	0.015
P	2	8.2500	.3750 / .4710	1.73	11.77	7.63	9.36	1-8 UNC-2B	1.0625 (3)	10.0000	0.030
W	2	10.4375	.5000 / .6280	1.98	15.02	9.38	11.36	1 1/8-7 UNC-2B	1.0938 (3)	12.7500	0.030
S	3	12.1250	.7500 / .8780	3.23	17.77	12.50	15.73	1 1/4-7 UNC-2B	1.3125 (3)	15.0000	0.030

NOTES

- 1) Taper angle 1°47' 24" ± 2' (per side) or 80% contact with on-size ring gage
- 2) All dimensions are prior to splitting
- 3) Only required for reverse mount
- 4) Angle may vary per manufacture's individual standards

Table 2 - Mating Hubs

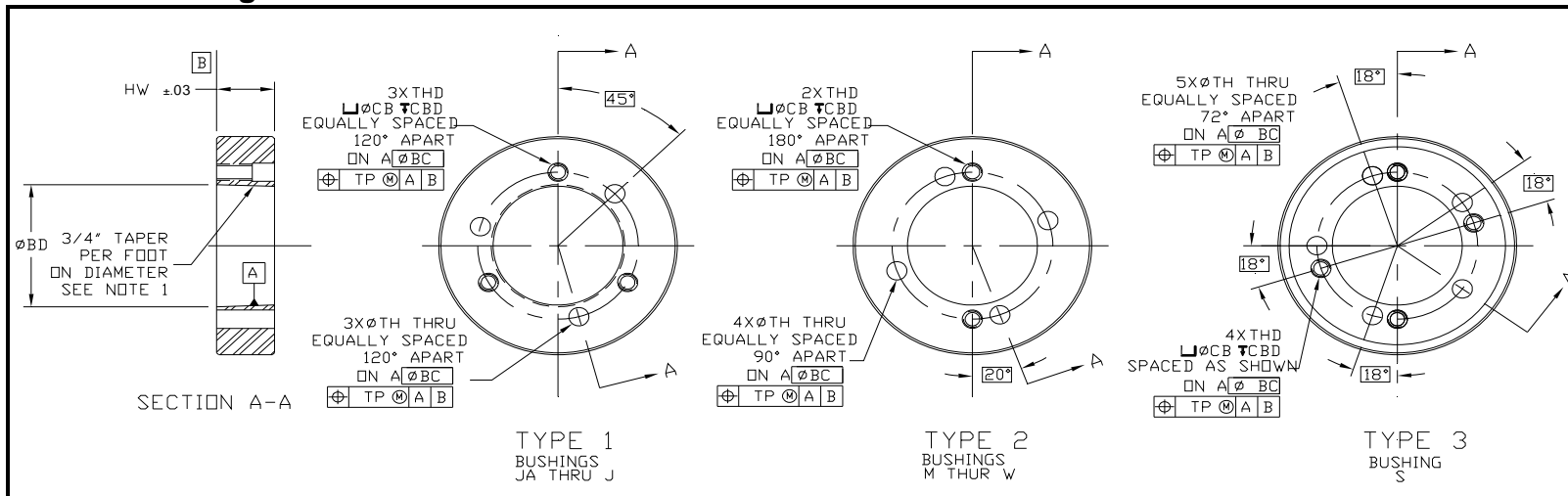

BUSHING	HUB TYPE	DIMENSIONS (IN)										
		LARGE END BORE DIAMETER BD		HUB WIDTH HW	THREADED BOLT HOLE					THRU HOLE MIN DIAMETER TH	THREADED AND THRU HOLE BOLT CIRCLE	
		Min	Max		THREAD SIZE THD	COUNTER BORE DIAMETER MIN. D	COUNTER BORE DEPTH CBD	COUNTER BORE DEPTH TOLERANCE CD	DIAMETER BC		TRUE POSITION TP	
JA	1	1.3730	1.3750	0.56	#10-24 UNC-2B	NONE	NONE	NONE	0.2190	1.6560	0.007	
SH	1	1.8680	1.8710	0.81	1/4-20 UNC-2B	0.2813	0.31	± .06	0.2813	2.2500	0.007	
SDS	1	2.1835	2.1875	0.75	1/4-20 UNC-2B	0.3125	0.25	± .06	0.3125	2.6875	0.007	
SD	1	2.1835	2.1875	1.25	1/4-20 UNC-2B	0.3125	0.75	± .06	0.3125	2.6875	0.007	
SK	1	2.8085	2.8125	1.25	5/16-18 UNC-2B	0.3438	0.62	± .06	0.3438	3.3125	0.007	
SF	1	3.1210	3.1250	1.25	3/8-16 UNC-2B	0.4375	0.56	± .06	0.4375	3.8750	0.015	
E	1	3.8300	3.8340	1.63	1/2-13 UNC-2B	0.5625	0.75	± .06	0.5625	5.0000	0.015	
F	1	4.4355	4.4395	2.50	9/16-12 UNC-2B	0.6250	1.50	± .12	0.6250	5.6250	0.015	
J	1	5.1410	5.1450	3.19	5/8-11 UNC-2B	0.6875	2.06	± .12	0.6875	6.2500	0.015	
M	2	6.4920	6.4960	5.19	3/4-10 UNC-2B	0.8125	3.94	± .12	0.8125	7.8750	0.015	
N	2	6.9900	6.9940	6.25	7/8-9 UNC-2B	0.9375	4.81	± .12	0.9375	8.5000	0.015	
P	2	8.2400	8.2440	7.25	1-8 UNC-2B	1.1250	5.56	± .12	1.1250	10.0000	0.030	
W	2	10.4270	10.4310	9.00	1 1/8-7 UNC-2B	1.2500	7.19	± .12	1.2500	12.7500	0.030	
S	3	12.1230	12.1270	12.00	1 1/4-7 UNC-2B	1.3750	9.25	± .12	1.3750	15.0000	0.030	

NOTES

- 1) Taper angle 1°47' 24" ± 2' (per side) and 80% contact with on-size plug gage
- 2) Bores measured with taper plug gage only.

Table 3 - FASTENERS

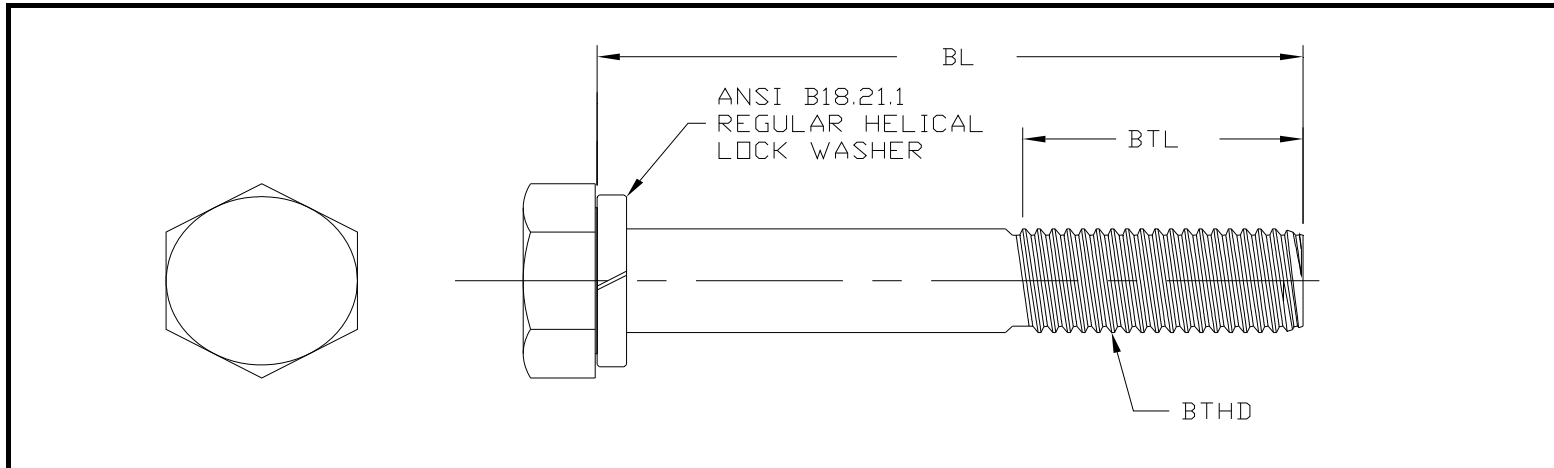

DIMENSIONS (IN)						
HEX HEAD CAP SCREW						
BUSHING	NUMBER OF SCREWS REQUIRED	THREAD SIZE BTHD	STANDARD MOUNT BOLT LENGTH BL	STANDARD MOUNT MIN THREAD LENGTH REQUIRED WITH WASHER BTL	REVERSE MOUNT BOLT LENGTH BL	REVERSE MOUNT MIN THREAD LENGTH REQUIRED WITH WASHER BTL
JA	3	#10-24 UNC-2A	1.00	1.00	1.00	1.00
SH	3	1/4-20 UNC-2A	1.38	1.13	1.13	1.13
SDS	3	1/4-20 UNC-2A	1.38	1.13	1.13	1.13
SD	3	1/4-20 UNC-2A	1.88	1.38	1.38	1.38
SK	3	5/16-18 UNC-2A	2.00	1.50	1.50	1.50
SF	3	3/8-16 UNC-2A	2.00	1.50	1.50	1.50
E	3	1/2-13 UNC-2A	2.75	1.88	1.88	1.88
F	3	9/16-12 UNC-2A	3.63	2.75	2.75	2.75
J	3	5/8-11 UNC-2A	4.50	3.38	3.38	3.38
M	4	3/4-10 UNC-2A	6.75	2.00	3.00	2.00
N	4	7/8-9 UNC-2A	8.00	2.25	3.50	2.25
P	4	1-8 UNC-2A	9.50	2.50	4.00	2.50
W	4	1 1/8-7 UNC-2A	11.50	2.75	4.50	2.75
S	5	1 1/4-7 UNC-2A	15.50	4.50	7.00	4.50

TABLE 4 - Mounting arrangement

