

Cast Iron Sheaves - **Light Duty**
Bored-to Size
for 3L, 4L or A Belts.
See pages 100-103

Order part number size + bore
Example: AKS42-1/2

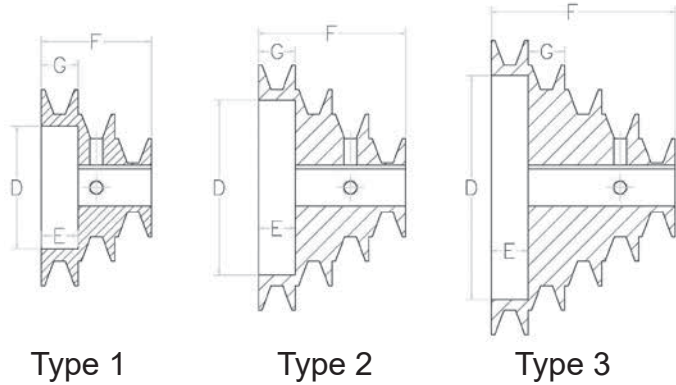

Type 1

Type 2

Type 3

Part No.	Type	Outside Diameters	Stock Bores	Dimensions (Inches)				Wt.
				D	G	F	E	
AKS62	3	6" 5" 4" 3" 2"	1/2-5/8-3/4-7/8	4 9/16	3/4	3 3/4	3/4	8.0
AKS63	2	6" 5" 4" 3"	1/2-5/8-3/4-7/8-1-1 1/8	4 9/16	3/4	3	3/4	7.5
AKS64	1	6" 5" 4"	1/2-5/8-3/4-7/8-1-1 1/8	4 9/16	3/4	2 1/4	3/4	6.5
AKS52	2	5" 4" 3" 2"	1/2-5/8-3/4-7/8	3 9/16	3/4	3	3/4	4.5
AKS53	1	5" 4" 3"	1/2-5/8-3/4-7/8-1-1 1/8	3 9/16	3/4	2 1/4	3/4	4.2
AKS42	1	4" 3" 2"	1/2-5/8-3/4-7/8	2 1/2	3/4	2 1/4	3/4	2.3

Standard Key Dimensions	
Shaft Dia.	Keyseat W x D
1/2	None
5/8 - 7/8	3/16 x 3/32
15/16 - 1 1/4	1/4 x 1/8

Step pulleys are accurately machined from gray cast iron, statically balanced, painted and individually packaged. They are furnished with standard keyway & 2 set screws. All set screws are 5/16-18 knurled. Recommended tightening torque is 110-130 inch-lbs.