

Cast Iron Sheaves - Light Duty
Bored-to-Size,
**One Groove and
Two Groove**
1VP and 2VP Dimensions

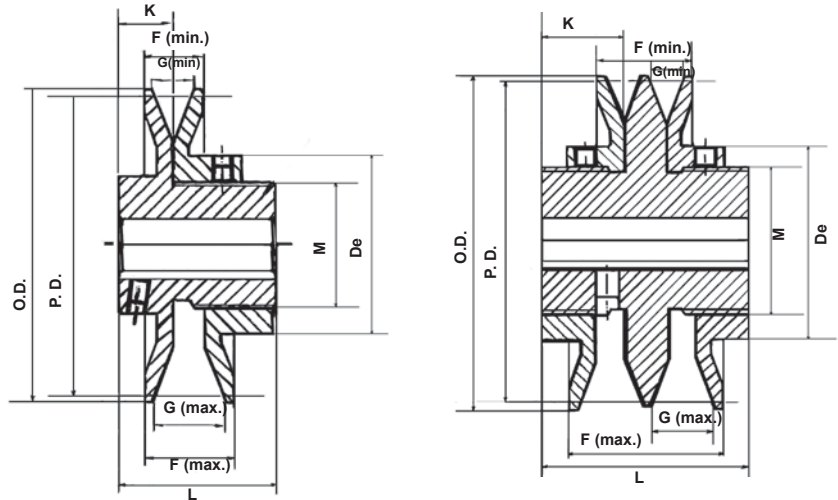

VP



1VP Sheaves may be used with 3L, 4L, 5L, A, B and 5V Belts. See pages 100-108 & 113.

Part No.	O.D.	F		G		L	K	Bore	M	De	Avg. Wt.
		Max	Min	Max	Min						
1VP25	2.380	0.810	0.560	0.630	0.380	1.590	0.620	1/2, 5/8, 3/4	1.375	2.00	1.0
1VP30	2.870	0.810	0.560	0.630	0.380	1.660	0.630	1/2, 5/8, 3/4	1.500	2.13	1.4
1VP34	3.150	1.000	0.690	0.810	0.500	1.880	0.780	1/2, 5/8, 3/4, 7/8, 1, 1 1/8	1.500 1.750	2.13 2.38	1.5 1.7
1VP40	3.750	1.060	0.690	0.880	0.500	1.880	0.660	1/2, 5/8, 3/4, 7/8, 1, 1 1/8	1.500 1.750	2.13 2.38	2.0 2.0
1VP44	4.150	1.060	0.690	0.880	0.500	1.880	0.660	1/2, 5/8, 3/4, 7/8, 1, 1 1/8	1.500 1.750	2.13 2.38	2.2 2.2
1VP50	4.750	1.060	0.690	0.880	0.500	2.000	0.780	1/2, 5/8, 3/4, 7/8, 1, 1 1/8	1.500 1.750	2.13 2.38	2.7 2.8
1VP56	5.350	1.060	0.690	0.880	0.500	2.000	0.780	1/2, 5/8, 3/4, 7/8, 1, 1 1/8	1.750	2.38	3.4
1VP60	6.000	1.250	0.880	1.031	0.660	2.160	0.850	5/8, 3/4, 7/8, 1 1/8, 1 3/8, 1 5/8	2.000 2.500	2.62 3.29	4.6 5.3
1VP62	5.950	1.250	0.880	1.031	0.660	2.000	0.780	5/8, 3/4, 7/8, 1, 1 1/8, 1 1/4, 1 3/8	2.000 2.500	2.62 3.29	4.6 5.1
1VP65	6.500	1.250	0.880	1.030	0.660	2.160	0.850	3/4, 7/8, 1 1/8, 1 3/8	2.000 2.500	2.62 3.29	5.3 5.8
1VP68	6.550	1.250	0.880	1.030	0.660	2.000	0.780	5/8, 3/4, 7/8, 1, 1 1/8, 1 1/4, 1 3/8	2.000 2.500	2.62 3.29	5.2 5.8
1VP71	7.100	1.250	0.880	1.030	0.660	2.160	0.850	3/4, 7/8, 1 1/8, 1 3/8, 1 5/8	2.000 2.500	2.62 3.29	6.5 6.8
1VP75	7.500	1.250	0.880	1.030	0.660	2.160	0.850	3/4, 7/8, 1 1/8, 1 3/8, 1 5/8	2.000 2.500	2.62 3.29	7.0 7.6

2VP Sheaves may be used with 3L, 4L, 5L, A, B and 5V Belts. See pages 100-108 & 113.

Part No.	O.D.	F		G		L	K	Bore	M	De	Avg. Wt.
		Max	Min	Max	Min						
2VP36	3.350	2.000	1.380	0.810	0.500	3.000	1.190	1/2, 5/8, 3/4, 7/8, 1, 1 1/8	2.000	2.62	3.8
2VP42	3.950	2.130	1.380	0.880	0.500	3.000	1.190	5/8, 3/4, 7/8, 1, 1 1/8	2.000	2.62	4.7
2VP50	4.750	2.130	1.380	0.880	0.500	3.000	1.190	5/8, 3/4, 7/8, 1, 1 1/8	2.125	2.75	6.3
2VP56	5.350	2.130	1.380	0.880	0.500	3.000	1.190	5/8, 3/4, 7/8, 1, 1 1/8, 1 3/8, 1 5/8	2.125 2.500	2.75 3.29	7.7 8.0
2VP60	6.000	2.380	1.630	1.030	0.660	3.250	1.250	3/4, 7/8, 1, 1 1/8, 1 3/8, 1 5/8	2.125 2.500	2.75 3.29	9.8 9.8
2VP62	5.950	2.380	1.630	1.030	0.660	3.000	1.190	3/4, 7/8, 1, 1 1/8, 1 3/8, 1 5/8	2.125 2.500	2.75 3.29	9.0 9.4
2VP65	6.500	2.380	1.630	1.030	0.660	3.250	1.250	3/4, 7/8, 1 1/8, 1 3/8, 1 5/8	2.125 2.500	2.75 3.29	11.0 12.2
2VP68	6.550	2.380	1.630	1.030	0.660	3.000	1.190	3/4, 7/8, 1, 1 1/8, 1 1/4, 1 3/8, 1 5/8	2.125 2.500	2.75 3.29	10.4 10.9
2VP71	7.100	2.380	1.630	1.030	0.660	3.250	1.250	3/4, 7/8, 1 1/8, 1 3/8, 1 5/8	2.125 2.500	2.75 3.29	13.4 14.3
2VP75	7.500	2.380	1.630	1.030	0.660	3.250	1.250	3/4, 7/8, 1 1/8, 1 3/8, 1 5/8	2.125 2.500	2.75 3.29	14.6 15.0

All 1VP & 2VP sheaves are furnished with standard keyway and (2) 5/16-18 knurled setscrews over each slot & in bore.

Light Duty Adjustable Sheaves

Cast Iron Sheaves - **Light Duty**
Bored-to Size,
One Groove
VL Sheaves

Order part number size
Example: 1VL25-5/8

VL Sheaves may be used with 3L,
4L, 5L, A and B Belts. See pages 100-105.

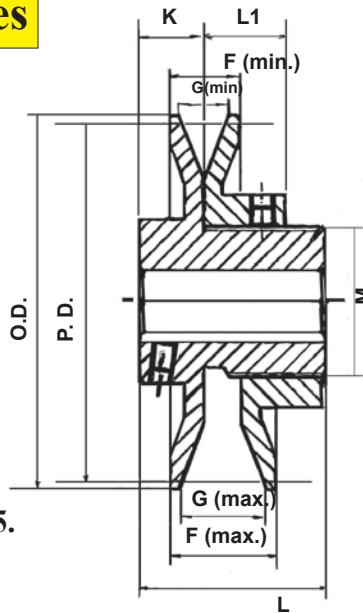

VL

All VL sheaves are furnished with standard keyway and (2) 5/16-18 x 5/16 knurled set screws.

Part No.	O.D.	F		G		L	L1	K	M	Bore	Avg. Wt.
		Max	Min	Max	Min						
1VL25	2.500	0.781	0.531	0.625	0.375	1.634	0.728	0.697	1.125	1/2, 5/8	.85
1VL30	2.870	0.781	0.531	0.625	0.375	1.634	0.728	0.697	1.125	1/2, 5/8	1.1
1VL34	3.150	1.000	0.625	0.875	0.500	1.933	0.815	0.744	1.125	1/2, 5/8,	1.1
									1.375	3/4	1.3
1VL40	3.750	1.000	0.625	0.875	0.500	1.933	0.815	0.744	1.125	1/2, 5/8,	1.5
									1.375	3/4, 7/8,	1.5
1VL44	4.150	1.000	0.625	0.875	0.500	1.933	0.815	0.744	1.125	1/2, 5/8,	1.6
									1.375	3/4, 7/8	1.7
1VM50	4.750	1.060	0.688	0.875	0.500	1.996	0.846	0.776	1.125	1/2, 5/8,	2.4
									1.375	3/4, 7/8	2.4

Cast Iron Sheaves - **Light Duty**
Bored-to Size,
One Groove
AL Sheaves

Order part number size
Example: no keyway = AL54-5/8, with keyway = AL54-5/8KW
AL Sheaves may be used with 4L, A Belts.

See pages 100-102.

AL Sheaves come with or without Keyway and are for Light Applications - Fans, Air Conditioning Units, Furnace Blowers etc.

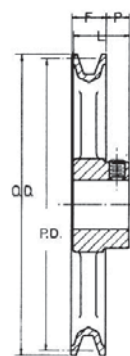

AL

Part No.	O.D.	Pitch	F	L	P	Bore	Hub O.D.	Avg. Wt.
AL54	4.93	4.78	.593	1.062	.468	5/8, 3/4, 1	1.7	1.2
AL64	5.93	5.78	.593	1.062	.468	5/8, 3/4, 1	1.7	1.4
AL74	6.93	6.78	.593	1.062	.468	5/8, 3/4, 1	1.7	1.7
AL84	7.93	7.78	.593	1.062	.468	5/8, 3/4, 1	1.7	1.9
AL94	8.93	8.78	.593	1.062	.468	3/4, 1	1.9	2.6
AL104	9.93	9.78	.593	1.062	.468	3/4, 1	2.0	3.0
AL114	10.93	10.78	.593	1.062	.468	3/4, 1	2.0	3.5
AL124	11.93	11.78	.593	1.062	.468	3/4, 1	2.0	4.0
AM144	14.16	14.00	.687	1.750	.406	1	2.0	5.2

Rework Charges for : Rebores, Keyways, additional setscrews - P.O.R. All AL sheaves are statically balanced and include (1) 5/16-18 knurled setscrew.

Part No.	DIAMETER RANGES											
	"3L" Belts				"4L" or "A" Belts				"5L" or "B" Belts			
	Min Pitch	Turns Open	Max. Pitch	Turns Open	Min. Pitch	Turns Open	Max. Pitch	Turns Open	Min. Pitch	Turns Open	Max. Pitch	Turns Open
1VL25	1.6	4	2.4	0	-	-	-	-	-	-	-	-
1VL30	1.8	4	2.7	0	-	-	-	-	-	-	-	-
1VL34	1.7	4	2.5	0	1.9	5	2.9	0	2.4	5	3.2	1
1VL40	2.3	4	3.1	0	2.4	5	3.4	0	2.7	6	3.7	1
1VL44	2.7	4	3.5	0	2.8	5	3.8	0	3.1	6	4.1	1
1VM50	3.3	4	4.1	0	3.4	5	4.4	0	3.7	6	4.7	1

Part No.	DIAMETER RANGES															
	"3L" Belts				"4L" or "A" Belts				"5L" or "B" Belts				"5V" Belts			
	Min Pitch	Turns Open	Max. Pitch	Turns Open	Min. Pitch	Turns Open	Max. Pitch	Turns Open	Min. Pitch	Turns Open	Max. Pitch	Turns Open	Min. Pitch	Turns Open	Max. Pitch	Turns Open
2VP36	1.9	4	2.7	0	2.0	5	3.0	0	2.5	5	3.3	1	-	-	-	-
2VP42	2.5	4	3.3	0	2.6	5	3.6	0	2.9	6	3.9	1	-	-	-	-
2VP50	3.3	4	4.1	0	3.4	5	4.4	0	3.7	6	4.7	1	-	-	-	-
2VP56	3.9	4	4.7	0	4.0	5	5.0	0	4.3	6	5.3	1	-	-	-	-
2VP60	-	-	-	-	4.2	5	5.2	0	4.3	6	5.5	0	4.7	6	5.9	0
2VP62	-	-	-	-	4.2	5	5.2	0	4.3	6	5.5	0	4.7	6	5.9	0
2VP65	-	-	-	-	4.7	5	5.7	0	4.8	6	6.0	0	5.2	6	6.4	0
2VP68	-	-	-	-	4.7	5	5.7	0	4.8	6	6.0	0	5.2	6	6.4	0
2VP71	-	-	-	-	5.3	5	6.3	0	5.4	6	6.6	0	5.8	6	7.0	0
2VP75	-	-	-	-	5.7	5	6.7	0	5.8	6	7.0	0	6.2	6	7.4	0

Part No.	DIAMETER RANGES															
	"3L" Belts				"4L" or "A" Belts				"5L" or "B" Belts				"5V" Belts			
	Min Pitch	Turns Open	Max. Pitch	Turns Open	Min. Pitch	Turns Open	Max. Pitch	Turns Open	Min. Pitch	Turns Open	Max. Pitch	Turns Open	Min. Pitch	Turns Open	Max. Pitch	Turns Open
1VP25	1.6	4	2.4	0	-	-	-	-	-	-	-	-	-	-	-	-
1VP30	1.8	4	2.7	0	-	-	-	-	-	-	-	-	-	-	-	-
1VP34	1.7	4	2.5	0	1.9	5	2.9	0	2.4	5	3.2	1	-	-	-	-
1VP40	2.3	4	3.1	0	2.4	5	3.4	0	2.7	6	3.7	1	-	-	-	-
1VP44	2.7	4	3.5	0	2.8	5	3.8	0	3.1	6	4.1	1	-	-	-	-
1VP50	3.3	4	4.1	0	3.4	5	4.4	0	3.7	6	4.7	1	-	-	-	-
1VP56	3.9	4	4.7	0	4.0	5	5.0	0	4.3	6	5.3	1	-	-	-	-
1VP60	-	-	-	-	4.2	5	5.2	0	4.3	6	5.5	0	-	-	-	-
1VP62	-	-	-	-	4.2	5	5.2	0	4.3	6	5.5	0	4.7	6	5.9	0
1VP65	-	-	-	-	4.7	5	5.7	0	4.8	6	6.0	0	5.2	6	6.4	0
1VP68	-	-	-	-	4.7	5	5.7	0	4.8	6	6.0	0	5.2	6	6.4	0
1VP71	-	-	-	-	5.3	5	6.3	0	5.4	6	6.6	0	5.8	6	7.0	0
1VP75	-	-	-	-	5.7	5	6.7	0	5.8	6	7.0	0	6.2	6	7.4	0

Installation and Operation Instructions

VL-VP FHP Adjustable Sheaves

- Loosen all setscrews on the sheave. Rotate the adjustable flange(s) to make the face width of the adjustable sheave the same as the face width of the companion sheave.
- Inspect the motor shaft and key for any nicks or burrs and remove if present. Install shaft key. Slide the sheave onto the motor shaft.
- Align the adjustable sheave with the companion sheave by using a straight edge or piece of string. This is most easily accomplished by using the four-point method shown below. Note: Dimensions, A, B, C and D must be equal for correct alignment.



- Secure the sheave to motor shaft by tightening the setscrew over the key to the proper torque (110-130 in. lbs. torque for 5/16" setscrews and 50-70 in. lbs. torque for 1/4"). Note: On two groove sheaves the setscrew is located at the base of the center flange. You may need to adjust the flange open to expose it.
- Adjust the sheave to the desired pitch diameter. Each turn of the flange changes the pitch diameter approximately .16 inches. Six turns are required to adjust the sheave from minimum to maximum for B (5L) belts, six turns for A (4L) belts, five turns for (3L) belts; and seven turns for (5V) belts. Note: You must adjust both flanges of a two-groove sheave equally so belts will ride evenly.
- Lock the adjustable flange(s) into position by tightening the setscrew(s) to the proper torque (5/16" setscrew – 110-130 in. lbs. torque, 1/4" setscrews – 60-70 in. lbs. torque). Warning: To prevent damage to hub threads, the set screw(s) must be over the flats or in the machined groove. If the flange is not properly locked, the sheave will fail prematurely.
- Install and properly tension belts.

WARNING

Rotating equipment can cause personal injury. BE SAFE install a guard around the drive to keep anything from coming into contact with moving parts.

- Start the drive. If a speed correction is necessary, stop the drive and remove the guard and belts. Adjust the sheave as per steps 5 through 7.